

Code of Alabama: § 32-9-(1-32)

www.dot.state.al.us

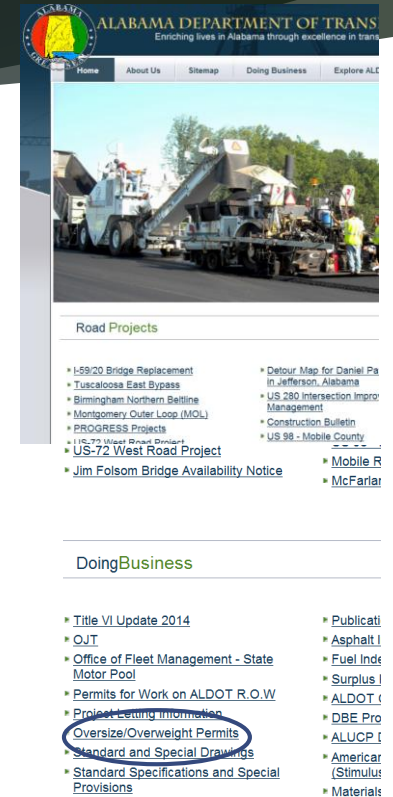

- ▶ Code of Alabama (1975), as amended
 - ▶ § 32-9-1 through § 32-9-32: Trucks, Trailers, and Semi-trailers; including Rules and Regulations for over-dimensional vehicles.

- ▶ Website:
<http://www.dot.state.al.us/maweb/Oversize&OverweightPermitInformation.htm>

Definitions of Terms Per §32-1-1.1 of the Highway Laws of Alabama, 2011

- ▶ **TRUCK:** Every motor vehicle designed, used, or maintained primarily for the transportation of property.
- ▶ **TRUCK TRACTOR:** Every motor vehicle designed and used primarily for drawing other vehicles and not so constructed as to carry a load other than **a part of the weight** of the vehicle and load so drawn.
- ▶ **TRAILER:** Every vehicle with or without motive power, other than a pole trailer, designed for carrying persons or property and for being drawn by a motor vehicle and so constructed that **no part of the weight** rests upon the towing vehicle
- ▶ **SEMITRAILER:** Every vehicle with or without motive power, other than a pole trailer, designed for carrying persons or property and for being drawn by a motor vehicle and so constructed that **some part of its weight** and that of its load rests upon or is carried by another vehicle.

Examples of these types are covered in next slides

Definitions of Terms Per §32-1-1(1) of the Highway Laws of Alabama, 2011

- ▶ **TRUCK:** Every motor vehicle designed, used, or maintained primarily for the transportation of property. Also known as a Cargo Carrying Vehicle.

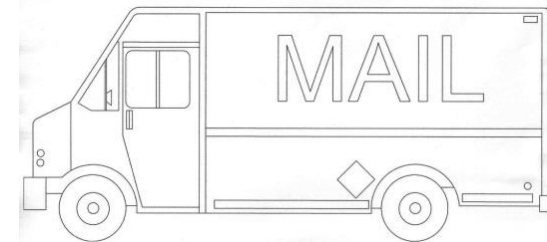
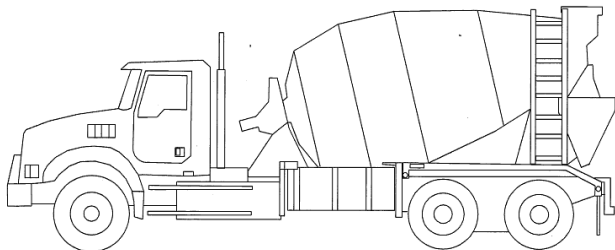
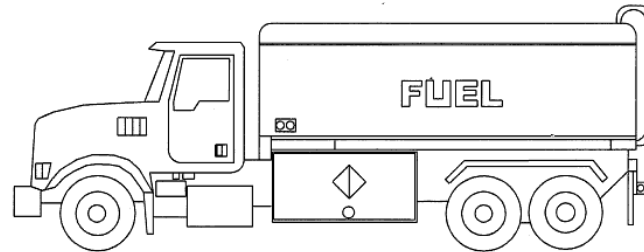
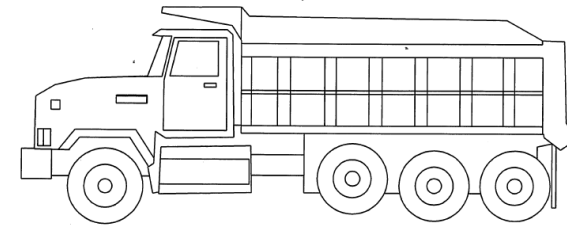
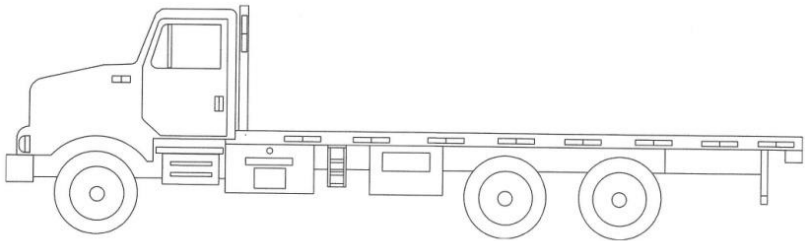

Definitions of Terms Per §32-1-1(1) of the Highway Laws of Alabama, 2011

- ▶ **TRUCK TRACTOR:** Every motor vehicle designed and used primarily for drawing other vehicles and not so constructed as to carry a load other than a **part of the weight** of the vehicle and load so drawn.

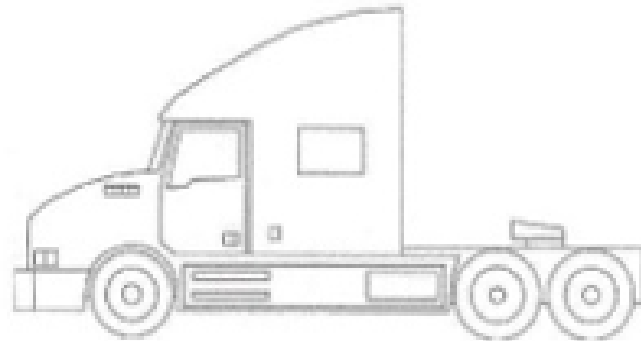

Article 2: Legal Limits

§ 32-9-20(1) Width

- ▶ Legal Width: 8' 6"
 - ▶ Total outside width including any load thereon, exclusive of mirrors and safety devices approved by ALDOT

Article 2: Legal Limits

§ 32-9-20(2) Height

- ▶ Legal Height: 13' 6"
 - ▶ Measured from the ground to the highest point on transported load

Article 2 – Size and Weight § 32-9-20(3) – Specifically, LENGTH

(3) LENGTH. – **No vehicle shall exceed in length 40 feet;**

EXCEPT, that the length of a truck-semi-trailer combination, semi-trailers, including load, used in a truck tractor-semi-trailer combination, shall not exceed 57 feet; semi-trailers and trailers, including load, used in a truck-tractor-semi-trailer-trailer combination, shall not exceed 28 ½ feet each; and motor vehicles designed, used, or maintained primarily as a mobile dwelling, office, or commercial space, commonly called motor homes, shall not exceed 45 feet.

§ 32-9-20(3) Length
Cargo Carrying Legal Length:
40'

No vehicle shall exceed, in length, 40'

The following are examples of straight trucks:

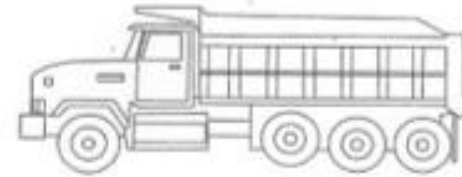
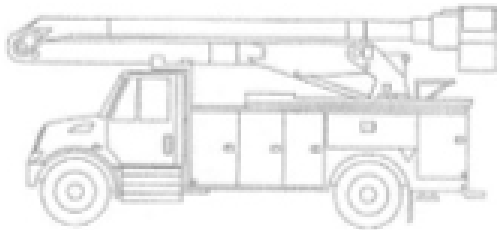
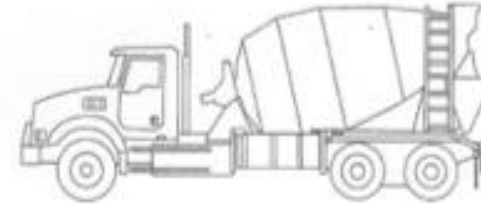
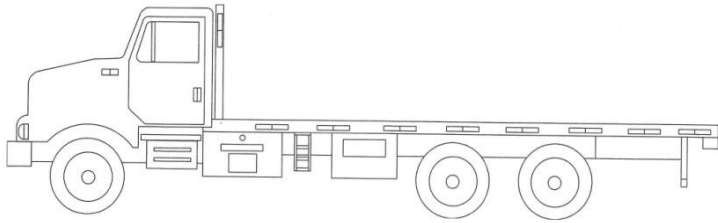

§ 32-9-20(3) Length Truck-Semitrailer Combination Legal Length: 57'

- ▶ **Truck-semitrailer combination**, semitrailers, including load, used in a truck-semitrailer combination, shall not exceed **57'**

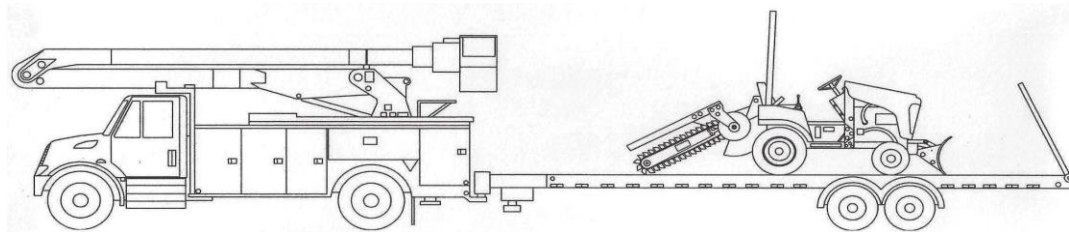
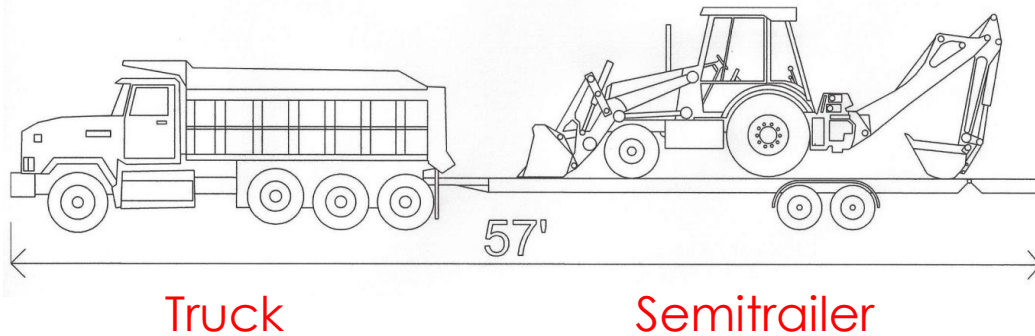

Examples of cargo carrying vehicle pulling trailer or semitrailer.

§ 32-9-20(3) Length
Semitrailer Legal Length:
57'

- ▶ Truck-semitrailer combination, **semitrailers**, including load, used in a truck tractor-semitrailer combination, shall not exceed **57'**

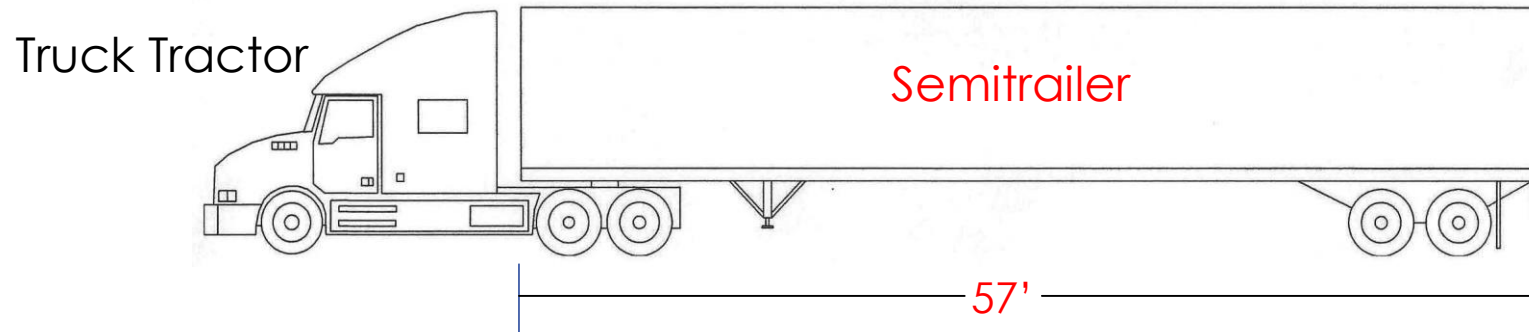

Maximum length of semitrailer: 57'

§ 32-9-20(3) Length

Legal Length:

57'

- ▶ Semitrailers and trailers, including load, used in a truck-tractor-**semitrailer-trailer** combination, shall not exceed **28.5'** each.

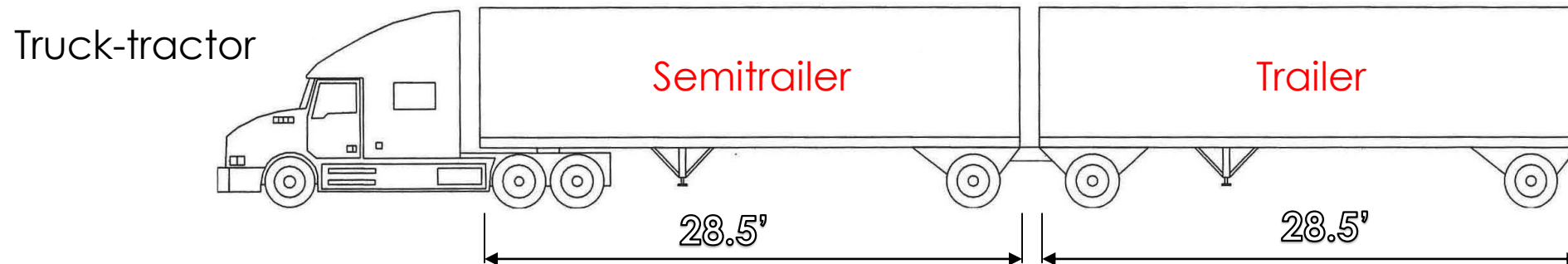

§ 32-9-20.3 Length

Motor Homes & Recreational Vehicles Legal Length:
45'

- ▶ **Motor Homes** (mobile dwelling, office, or commercial space) shall not exceed **45'**



§ 32-9-20(3) Length
Motor Homes With Attachment Legal Length:
57'

- ▶ **Motor Homes** (mobile dwelling, office, or commercial space) pulling a **semitrailer** or **trailer** shall not exceed **57'** in total length.



Maximum length of motor home pulling a semitrailer or trailer: 57'

§ 32-9-20(3) Length

Truck-Semitrailer Combinations Used Exclusively
for Transporting Automobiles Legal Length:

65'

- ▶ Truck tractor units used exclusively in combinations **transporting motor vehicles** may directly carry a portion of the cargo, provided that the combinations are restricted to truck tractor-semi-trailer combinations only and provided further that the overall length of the particular combinations shall not exceed **65 feet**.

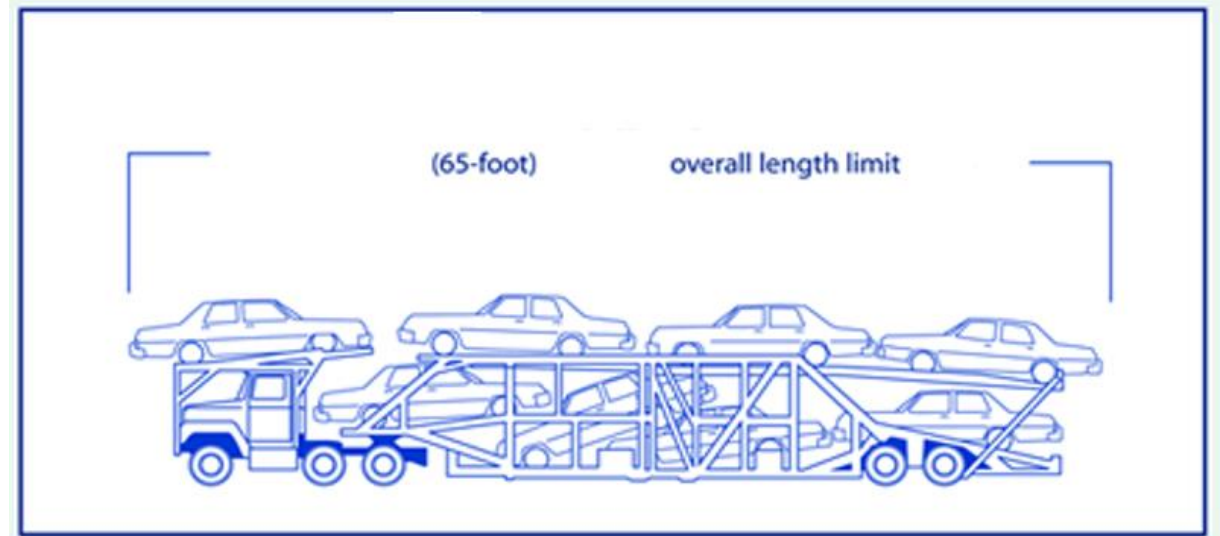

§ 32-9-20(3) Length

Truck-Semitrailer Combinations Used Exclusively for Transporting Automobiles Using a Stinger-Steered Unit Legal Length:

75'

- ▶ The overall length of Stinger-Steered type units shall not exceed 75 feet:

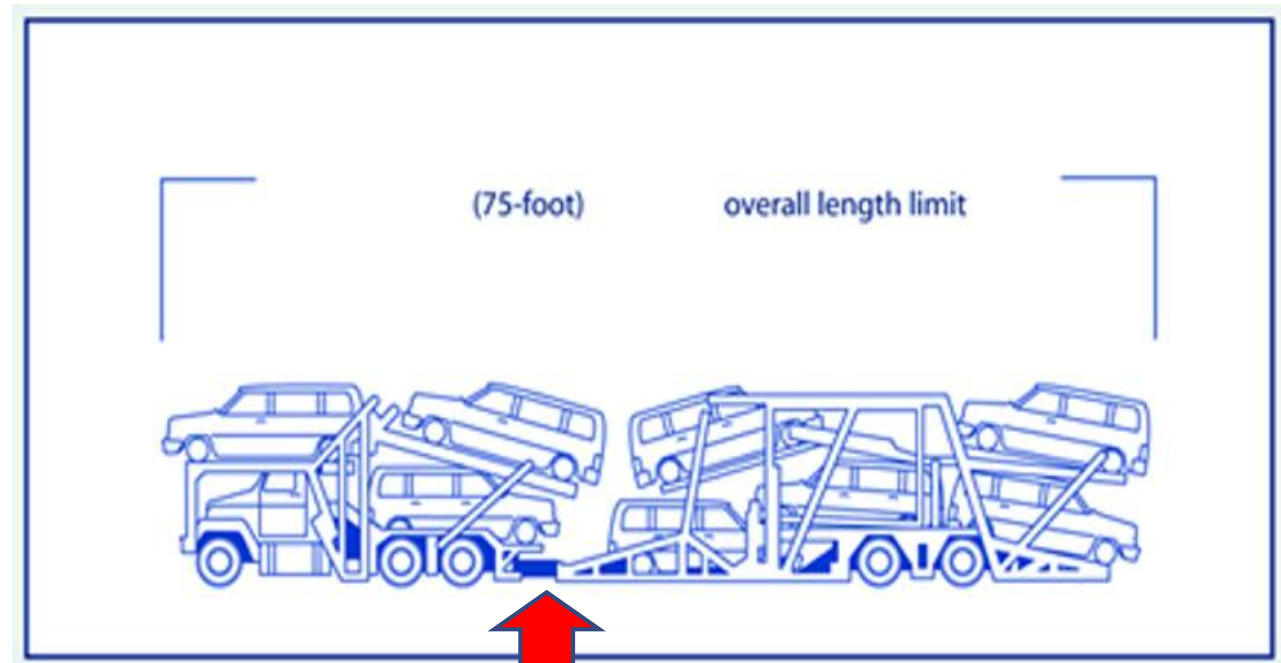

Stinger-Steered Unit

§ 32-9-20(3) Length
Legal Overhang Length:
5'

Maximum Legal Overhang (Front and Rear) = 5'
Overhang shall be included in the overall length of
vehicle or combination of vehicle.

§ 32-9-29, Code of Alabama (1975): Permits for Movement of Oversize Vehicles or Loads

- ▶ The Highway Director or the official of the Highway Department designated by the director may, in his discretion, upon application and for good cause being shown therefore, issue a permit in writing authorizing the applicant to operate or move upon the State Highway System a vehicle or combination of no more than two vehicles and loads whose weight, width, length, or height, or combination thereof, exceeds the maximum limit specified by law.
- ▶ **Load must be reduced to smallest size and still exceed legal dimensions to qualify for a permit**
 - ▶ No permit shall be issued for transporting a load that can readily be dismantled or separated; however, bulldozers and similar construction equipment shall not be deemed readily separable.

PERMIT TYPES

Permit Types

- ✓ **Single Trip Permit**
 - ✓ Valid for 5 days
 - ✓ Valid for One Round Trip – empty to destination, hauling load back, or vice-versa
 - ✓ Mobile Homes – maximum permissible dimensions = 16' wide x 16' high
- ✓ **Annual Permit**
 - ✓ Valid for One Year
 - ✓ Vehicle Specific – VIN # on the Annual Permit MUST match the VIN # on the transport vehicle
 - ✓ Available for:
 - ✓ Vehicle/Load (Over Dimensional and/or Overweight)
 - ✓ Need “Routing Authorization” permit for gross weights over 100,000 lbs.
 - ✓ Routing Authorization from Permit Office must accompany the Annual Permit and be in the Vehicle
 - ✓ Mobile Homes – maximum permissible dimensions = 14' wide x 14' high
 - ✓ Need “Routing Authorization” permit for Mobile Homes ≥ 12' wide up to maximum 14' wide
 - ✓ Routing Authorization from Permit Office must accompany the Annual Permit
 - ✓ Modular Homes, Sectional Houses, Portable Buildings, Boats and vehicles or combination of vehicles greater than 12 feet wide
 - ✓ Sealed Containers – maximum permissible weight = 100,000lbs; Open top containers may be considered on a case by case basis(NOTE: All trucks transporting Sealed Containers must carry a bill of lading and equipment interchange report or receipt in the cab of the truck.)



Major Changes in Rules and Regulations in Result of Nationwide Harmonization Initiative

Requirements Before June 1, 2017

Warning Signs on **Transporting Vehicle**

- ▶ **Flags**
 - ▶ Size: 18" x 18" Minimum
 - ▶ Color: Red
 - ▶ Location: all four corners of the load
- ▶ **Sign**
 - ▶ Size: 18" x 7'
 - ▶ Color: Black letters on a Yellow or Orange background
 - ▶ Message: OVERSIZE LOAD;
 - ▶ *"Wide Load" is NOT acceptable*
 - ▶ Size of Letters: 10" x 1-5/8"
 - ▶ Location: Front and Rear of the transport vehicle

Harmonization Initiative with other States Requirements After June 1, 2017

Warning Signs & Lights on **Transporting Vehicle**

- ▶ **Flags**
 - ▶ Size: 18" x 18" minimum
 - ▶ Color: Fluorescent Orange or Red
 - ▶ Location: Four corners of load or extremities (length)
- ▶ **Sign**
 - ▶ Size of sign: 18" x 7'
 - ▶ Color: Black letters on a Yellow background
 - ▶ Message: OVERSIZE LOAD
 - ▶ *"Wide Load" is NOT Acceptable*
 - ▶ Size of letters: 10" x 1.4" – 1.5"
 - ▶ Location: Front and Rear of the Transport Vehicle so that license plate and headlights are not blocked
- ▶ **Transport Warning Lights (Minimum)**
 - ▶ Flashing or Strobe Amber Light
 - ▶ Visible for 500', 360° degrees

Requirements Before June 1, 2017

Warning Signs and Lights on [Escort Vehicle](#)

- ▶ Size of Signs: 18" x 7' (May be smaller to fit vehicle size so that "OVERSIZE LOAD" is clearly visible.)
- ▶ Message: OVERSIZE LOAD; *"Wide Load" is NOT acceptable*
- ▶ Color: Black letters on a Yellow or Orange background
- ▶ Size of Letters: 10" x 1-5/8"
- ▶ Location of Signs:
 - ▶ Front of the escort vehicle on a front escort
 - ▶ Rear of the escort vehicle on a rear escort
- ▶ Escort Warning Lights (Minimum)
 - ▶ Flashing or Revolving Amber Light
- ▶ Escort Vehicles shall be able to contact each other and the permitted vehicle or combination of vehicles and loads by radio

Harmonization Initiative with other States Requirements After June 1, 2017

Warning Signs and Lights on [Escort Vehicle](#)

- ▶ Size of Signs: 18" x 7' (May be smaller to fit vehicle size so that "OVERSIZE LOAD" is clearly visible.)
- ▶ Message: OVERSIZE LOAD; *"Wide Load" is NOT acceptable*
- ▶ Color: Black letters on a Yellow background
- ▶ Size of Letters: 10" x 1.4" – 1.5"
- ▶ Location:
 - ▶ Front of Front Escort and Rear of Rear Escort OR
 - ▶ Above Roofline of Escort where it is visible from the front and rear
- ▶ Escort Warning Lights (Minimum)
 - ▶ Flashing or Strobe Amber Light
 - ▶ Visible for 500', 360°degrees

Requirements Before June 1, 2017

Escort Requirements for **Equipment**:

- ▶ Overwidth: >12' = 1 Front and 1 Rear Escort
- ▶ Overheight:
 - ▶ >15'6" = 1 Front Escort with height pole
 - ▶ Additional escorts may be required, depending on route or other dimensions
- ▶ Overlength:
 - ▶ 76' – 105' (inclusive) = 1 Rear Escort
 - ▶ >105' – 150' = 1 Front Escort and 1 Rear Escort
- ▶ Overhang:
 - ▶ ≥10' Front Overhang = 1 Front Escort
 - ▶ >5' Rear Overhang = 1 Rear Escort

Harmonization Initiative with other States Requirements After June 1, 2017

Escort Requirements for **Equipment**:

- ▶ Overwidth:
 - ▶ >12' – 14' = 1 Front Escort on Two-lane Roads, or 1 Rear Escort on Multi-lane Highways.
 - ▶ >14' = 1 Front and 1 Rear Escort
- ▶ Overheight:
 - ▶ >15'6" = 1 Front Escort with Height Pole
- ▶ Overlength:
 - ▶ >90' – 125' = 1 Rear Escort
 - ▶ >125' = 1 Front Escort and 1 Rear Escort
- ▶ Overhang:
 - ▶ ≥ 10' Front Overhang = 1 Front Escort
 - ▶ > 5' Rear Overhang = 1 Rear Escort

Escort Requirements after June 1, 2017

Escorts:

Escort vehicles shall be a properly licensed, single-unit vehicle (e.g. passenger automobile, pick-up truck, or SUV) with an unobstructed view and clear line of sight in all directions. A flatbed truck or service vehicle may be used as long as it maintains an unobstructed view and clear line of sight in all directions. No vehicle towing a trailer can be used as an escort vehicle. Escort vehicles must be equipped with flashing or strobe amber lights, visible 360 degrees at 500 feet. The escort's headlights shall be set at low beam at all times. All vehicles supporting the move shall be able to contact each other, including escort vehicles, law enforcement escorts, and the permitted vehicle. A sign shall be mounted on the front and rear of any escort vehicle or above the roofline where it is visible from the front and rear. The sign shall contain the wording "OVERSIZE LOAD" in black letters on a yellow background. The size of the sign shall be relative to the size of the escort vehicle so that the entire message may be seen completely and clearly. The letters shall be ten (10) inches high with a 1.4" – 1.5" brush stroke. No other signage is allowed. The banner shall only be attached or visible during the transportation of the permitted load.

Escort Requirements after June 1, 2017

Escorts:

The non-emergency use of cell phones or other portable electronic devices, other than those designated to support the movement of the specific oversize combination vehicle, except to communicate hazard-related information, is prohibited.

Mobile Home Escort Requirements after June 1, 2017

Overwidth: >12' = 1 Front and 1 Rear Escort

- ▶ **Two Lane Highways**

- ▶ 1 FRONT Escort **IN ADDITION TO** the [Approved Lighting System](#) on the rear of the Mobile Home.

- ▶ **Multiple Lane Highways**

- ▶ 1 REAR Escort **IN ADDITION TO** the [Approved Lighting System](#)

Overheight: >15'6" = 1 Front Escort with height pole.

- ▶ Additional escorts may be required for lesser heights depending on the route traveled.

Mobile Home Escort Requirements after June 1, 2017

[The Approved Lighting System:](#)

For mobile homes, the rear escort may be replaced by the following described lighting system: Two flashing or strobe lights, visible for 360 degrees at 500 feet shall be mounted six (6) feet above ground level on the rear corners of the mobile home, in addition to all required ALDOT safety and warning devices. Control of the lighting system shall be inside the tractor cab with a warning device to alert the driver in the event the lights malfunction. If a light malfunctions, the driver is to proceed to the first area where the load can be safely removed from the roadway and parked until the lighting system is repaired.

Mobile Home Escort Requirements after June 1, 2017

Escorts:

Mobile home escorts shall be located in the front on two-lane roads and shall move to the rear of mobile home on multi-lane roads, even with the approved lighting system, and shall assume the duties of a rear escort.

Requirements Before June 1, 2017

- ▶ Oversize loads can move between 30 minutes after sunset and 30 minutes before sunrise
- ▶ Oversize loads CANNOT move on:
 1. New Year's Day
 2. Independence Day
 3. Labor Day
 4. Thanksgiving Day
 5. Christmas Day

Harmonization Initiative with other States Requirements After June 1, 2017

- ▶ Oversize loads can move during **Daylight Hours Only**
- ▶ Oversize loads are not allowed movement on:
 1. New Year's Day
 2. **Memorial Day**
 3. Independence Day
 4. Labor Day
 5. Thanksgiving Day
 6. Christmas Day

www.dot.state.al.us

ALABAMA DEPARTMENT OF TRANSPORTATION
Enriching lives in Alabama through excellence in transit

Home About Us Sitemap Doing Business Explore ALDOT

Road Projects

- I-99/20 Bridge Replacement
- Tuscaloosa East Bypass
- Birmingham Northern Beltline
- Montgomery Outer Loop (MOL)
- PROGRESS Projects
- US-98 Mobile County
- Detour Map for Daniel P. Tate in Jefferson, Alabama
- US-280 Intersection Improvements Management
- Construction Bulletin
- US-98 - Mobile County

Doing Business

- Title VI Update 2014
- OJT
- Office of Fleet Management - State Motor Pool
- Permits for Work on ALDOT R.O.W
- Project Letting Information
- **Oversize/Overweight Permits**
- Standard and Special Drawings
- Standard Specifications and Special Provisions
- Publications
- Asphalt
- Fuel Index
- Surplus
- ALDOT
- DBE Programs
- ALUCP
- American Stimulus
- Materials

Alabama Oversize/Overweight Permit Office Contact Information and Website

Alabama Department of Transportation
Vehicle Enforcement Office
Montgomery, Alabama

Hours of Operation:
Monday through Friday
7:00 AM until 4:45 PM
CST



Contact Information:
Toll Free: 800-499-2782
Fax: 334-832-9084

Mailing Address:
P. O. Box 303050
Montgomery, AL 36130

alabamapermits@dot.state.al.us
(When sending e-mails, be sure to use the subject line to direct information to the correct person.)

Click [HERE](#) for the latest DETOUR information that may affect your current Permit or Routing Authorization (updated October 1, 2014)

Please contact the Permit Office for Detour Routing Information

Permitting Oversize/Overweight Loads
Please read and understand the following to make sure the permit process is as smooth as possible

PHONE:

800-499-2782

334-834-1092

FAX:

334-832-9084

WEBSITE:

[HTTP://WWW.DOT.STATE.AL.US/MAWEB/OVERSIZE&OVERWEIGHTPERMITINFORMATION.HTM](http://www.dot.state.al.us/MAWEB/OVERSIZE&OVERWEIGHTPERMITINFORMATION.HTM)